

# Articulated feet base in reinforced polyamide

Part. **93** Ø**124**

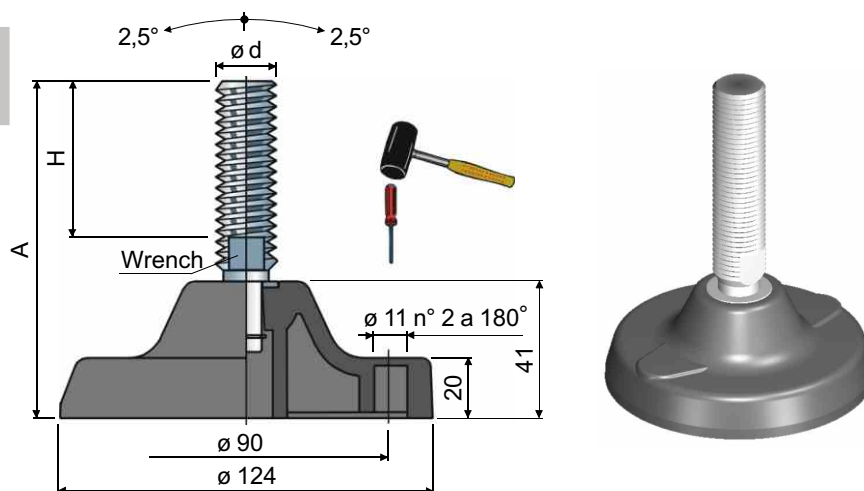

Ø d	A mm	H mm	Wrench mm	Spindle in zinc plated steel	Spindle in stainless steel AISI 304	Max static load N
				Code/Codice	Code/Codice	
<b>M16</b>	115	58	13	<b>93 / 7510</b>	<b>93 / 7511</b>	43000
	176	119	13	<b>93 / 7908</b>	<b>93 / 7909</b>	
	202	145	13	<b>93 / 7512</b>	<b>93 / 7513</b>	
	258	201	13	<b>93 / 7514</b>	<b>93 / 7515</b>	
<b>M20</b>	167	107	17	<b>93 / 7516</b>	<b>93 / 7517</b>	45000
	195	135	17	<b>93 / 7518</b>	<b>93 / 7519</b>	
	217	157	17	<b>93 / 7520</b>	<b>93 / 7521</b>	
<b>M24</b>	153	90	19	<b>93 / 7522</b>	<b>93 / 7523</b>	47000
	190	127	19	<b>93 / 7524</b>	<b>93 / 7525</b>	
	225	162	19	<b>93 / 7526</b>	<b>93 / 7527</b>	
<b>M30</b>	188	125	24	<b>93 / 7528</b>	<b>93 / 7529</b>	50000
	248	185	24	<b>93 / 7530</b>	<b>93 / 7531</b>	

**Base material:** reinforced polyamide.

**Packaging:** 8 pieces.

## Accessories

**Anti-slip pads:**

- code: 7633;

material: PVC rubber (black);

packaging: 8 pieces.

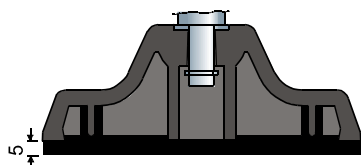

**Nuts UNI 5588-65 - Packaging: 24 pieces.**

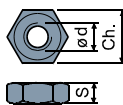

Ø d	M16	M20	M24	M30
Smm	13	16	19	24
Ch. mm	24	30	36	46
Zinc plated steel code	7275	7276	7279	7281
Stainless steel code	7277	7278	7280	7282

**Washers UNI 6592-69 - Packaging: 24 pieces.**

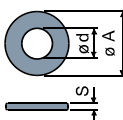

Ø d mm	17	21	25	31
Smm	3	3	4	4
Ø A mm	30	37	44	56
Zinc plated steel code	7289	7290	7293	7295
Stainless steel code	7291	7292	7294	7296

## On request

**Bases:** In reinforced polypropylene • other colours • with prebored fixing holes.

**Spindles with:** Sunk hexagon head • second wrench seat head • hexagon wrench seat • threads with other pitches and lengths.

**Packaging:** not standard.

**Assembling of:** Anti-slip pads • nuts • washers.